

Head Parts Breakdown

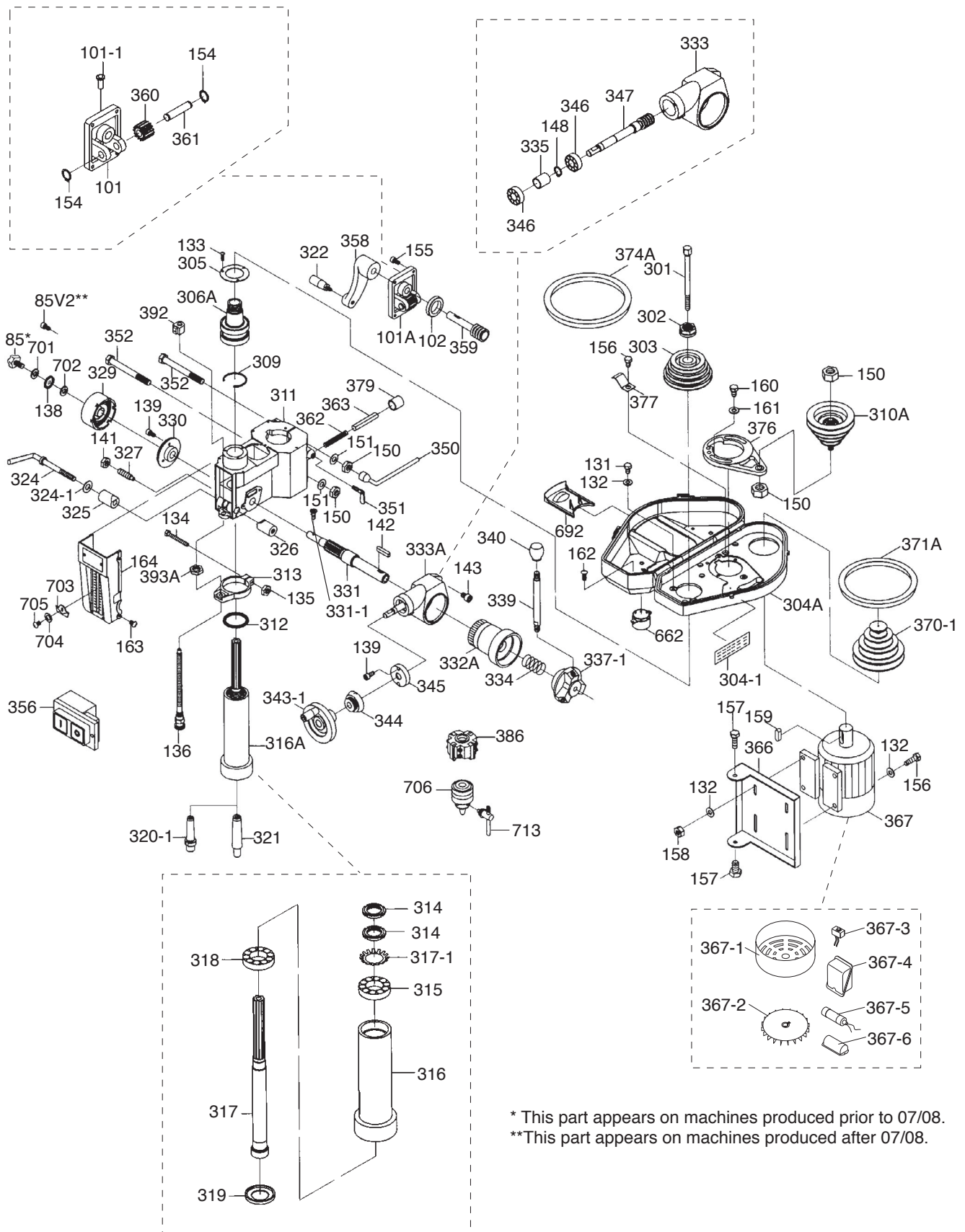

* This part appears on machines produced prior to 07/08.
 **This part appears on machines produced after 07/08.



Head Parts List

REF	PART #	DESCRIPTION	REF	PART #	DESCRIPTION
85	PSW03-1	KNOB	325	P1006325	CLAMP COLLAR
85V2	PSB01	CAP SCREW 1/4-20 X 5/8	326	P1006326	CLAMP NUT 3/8-16
101	P1006101	CRANK BRACKET	327	P1006327	SPECIAL SCREW 3/8-16 X 38
101-1	P1006101-1	OIL CUP	329	P11261103	SPRING COVER ASSY
101A	P1006101A	CRANK BRACKET ASSEMBLY	330	P1006330	SPRING BASE 76 X 76 X 19
102	P1006102	WORM SHAFT BUSHING	331	P1006331	PINION SHAFT
131	PB07	HEX BOLT 5/16-18 X 3/4	331-1	PS01	PHLP HD SCR 10-24 X 1/2
132	PW07	FLAT WASHER 5/16	332A	P1006332A	FINE FEED CLUTCH ASSEMBLY
133	PS04	PHLP HD SCR 1/4-20 X 1/2	333	P1006333	FINE FEED HOUSING
134	PB10	HEX BOLT 1/4-20 X 2	333A	P1006333-1	FINE FEED ASSEMBLY
135	PN05	HEX NUT 1/4"-20	334	P1006334	SPRING 27 X 17.5 X 17.5
136	P1006136	GRADUATED ROD ASSY	335	P1006335	BEARING SPACER 34 X 28
138	P1014116	FENDER WASHER 1/4	337-1	P1006337-1	HANDLE BASE ASSY
139	PS01	PHLP HD SCR 10-24 X 1/2	339	P1006339	HANDLE ROD
141	PN08	HEX NUT 3/8"-16	340	P1006340	ROUND KNOB
142	PK25M	KEY 7 X 7 X 20	343-1	P1006343-1	HANDWHEEL ASSY
143	PSB07	CAP SCREW 5/16-18 X 3/4	344	P1006344	GRADUATED DIAL
148	PR05M	EXT RETAINING RING 15MM	345	P1006345	SLEEVE
150	PN04	HEX NUT 5/8"-11	346	P6202	BALL BEARING 6202ZZ
151	PLW06	LOCK WASHER 5/8	347	P1006347	WORM SHAFT
154	PR02M	EXT RETAINING RING 14MM	350	P1006350	HEAD WRENCH
155	PSB05	CAP SCREW 1/4-20 X 3/4	351	P1006351	THUMB SCREW 3/8-16
156	PB03	HEX BOLT 5/16-18 X 1	352	PB46	HEX BOLT 5/8-11 X 6
157	PB38	HEX BOLT 7/16-14 X 2	356	P1006356	ON/OFF SWITCH
158	PN02	HEX NUT 5/16"-18	358	P1006358	ELEVATION CRANK
159	P1006159	KEY 7 X 7 X 37	359	P1006359	WORM GEAR SHAFT
160	PB11	HEX BOLT 5/16-18 X 1-1/2	360	P1006360	PINION GEAR
161	PW07	FLAT WASHER 5/16	361	P1006361	GEAR AXLE
162	PB12	HEX BOLT 5/16-18 X 1-1/4	362	P1006362	COMPRESSION SPRING 13 X 83
163	PS04	PHLP HD SCR 1/4-20 X 1/2	363	P1006363	MOTOR POSITION PIN
164	P1006164	FRONT COVER PLATE ASSEMBLY	366	P1006366	MOTOR BASE
301	P1126102	DRAWBAR 7/16-20 x 442L	367	P1006367	2HP MOTOR 110/220V SINGLE PHASE
302	P1006302	SPINDLE NUT 42-16 V1.08.97	367-1	P1006367-1	MOTOR FAN COVER
303	P1006303	SPINDLE PULLEY	367-2	P1006367-2	MOTOR FAN
304-1	P1006304-1	SPEED CHART LABEL	367-3	P1006367-3	CIRCUIT BREAKER BUTTON
304A	P1006304A	BOTTOM BELT COVER	367-4	P1006367-4	JUNCTION BOX
305	P1006305	OUTER BEARING COVER	367-5	PC150D	S CAPACITOR 150M 250V 1-3/8 X 2-3/4
306A	P1006306A	TAPERED SPINDLE SLEEVE LH V2.12.98	367-6	P1006367-6	CAPACITOR COVER
309	PR52M	EXT RETAINING RING 80MM	370-1	P1006370-1	MOTOR PULLEY SET
310A	P1006310A	IDLER PULLEY ASSEMBLY	371A	PVB34	V-BELT B-34 5L340
311	P1006311	HEAD CASTING	374A	PVB42	V-BELT B-42 5L420
312	P1006312	RUBBER RING	376	P1006376	PULLEY SWING BASE
313	P1006313	QUILL COLLAR	377	P1006377	CLIP PLATE
314	P1006314	TAKE UP NUT	379	P1006379	RUBBER COLLAR
315	P30206	TAPERED ROLLER BEARING 30206	386	P1006386	FACE CUTTER
316	P1006316	QUILL	392	P1006392	POSITION SET BRACKET
316A	P1006316A	QUILL ASSEMBLY	393A	P1006393A	FIXED NUT
317	P1006317	SPINDLE SHAFT	662	P1006662	DRAW BOLT COVER 75 X 54 X 42.5
317-1	P1006317-1	SPECIAL STAR WASHER	692	P1006692	BELT COVER LID
318	P1006318	BEARING 30207J	701	PLW02	LOCK WASHER 1/4
319	P1006319	BEARING CAP	702	PW06	FLAT WASHER 1/4
320-1	P1006320-1	CUTTER ARBOR ASSY	703	P1006703	LIMIT PLATE
321	P1006321	CHUCK ARBOR	704	P1006704	FLAT WASHER 1/8
322	P1006322	HANDLE BOLT 3/8-16	705	P1006705	PHLP HD SCR 5-40 X 3/8
324	P1006324	QUILL LOCK HANDLE	706	P1006706	CHUCK 1/2"-JT6
324-1	PW01	FLAT WASHER 1/2	713	P1006713	CHUCK KEY



Column & Table Parts Breakdown

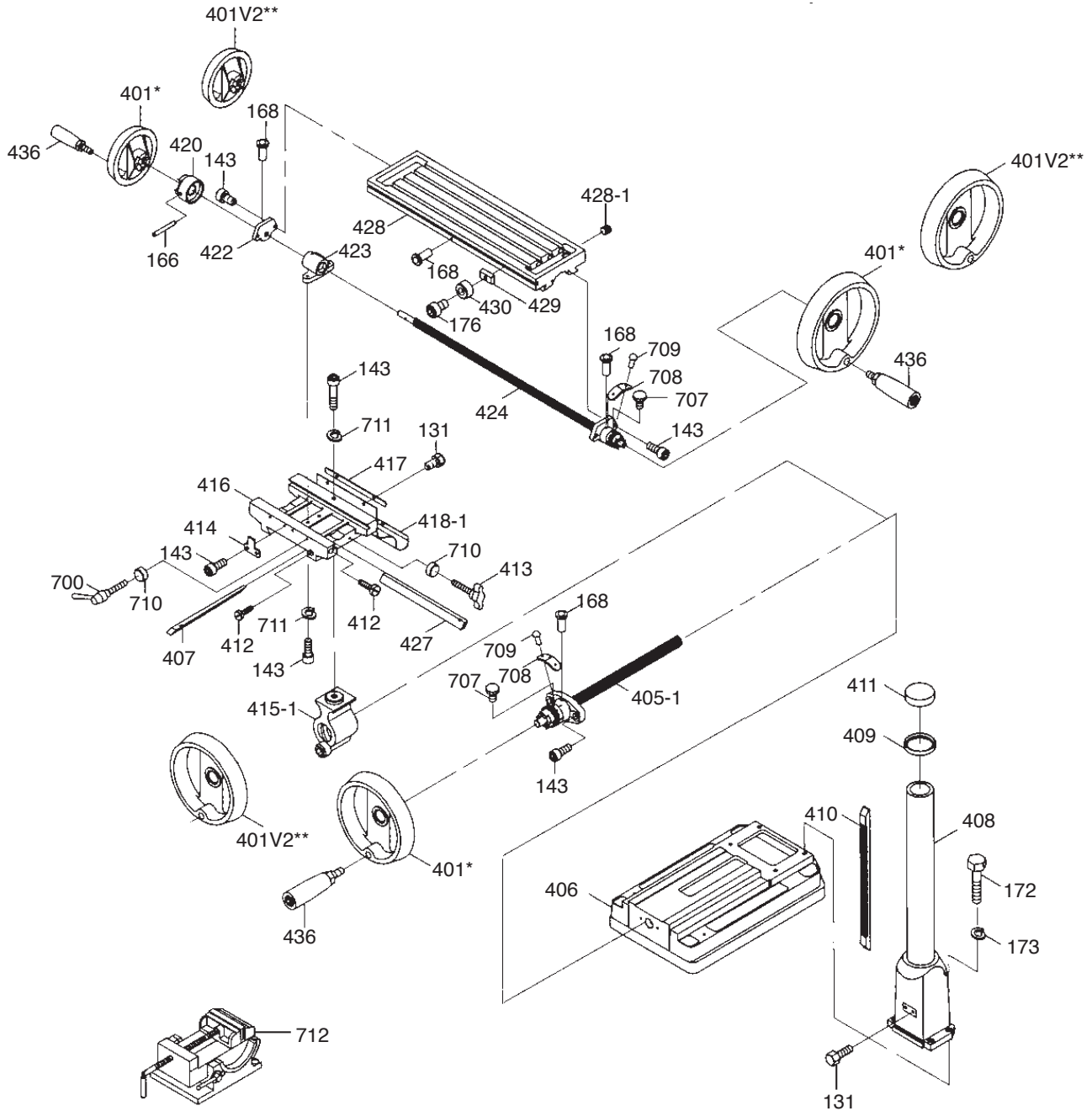

* This part appears on machines produced prior to 07/08.

**This part appears on machines produced after 07/08.



Column & Table Parts List

REF	PART #	DESCRIPTION
131	PB07	HEX BOLT 5/16-18 X 3/4
143	PSB07	CAP SCREW 5/16-18 X 3/4
166	PRP10M	ROLL PIN 5 X 36
168	P1006168	OIL CUP
172	PB64	HEX BOLT 5/8-11 X 2-1/2
173	PLW06	LOCK WASHER 5/8
176	PSB04	CAP SCREW 1/4-20 X 1/2
401	P1126201	HANDWHEEL W/HANDLE
401V2	P1006401V2	PLASTIC HANDWHEEL W/HANDLE V2.07.08
405-1	P1006405-1	ACME SCREW ASSY
406	P1006406	BASE
407	P1006407	SADDLE GIB
408	P1006408	COLUMN
409	P1006409	COLUMN FLANGE RING
410	P1006410	RACK
411	P1006411	COLUMN CAP
412	P1006412	GIB SCREW 5/16-18 X 35
413	P1006413	TABLE LOCK
414	P1006414	TABLE STOP
415-1	P1006415-1	CROSS LEADSCREW NUT ASSY

REF	PART #	DESCRIPTION
416	P1006416	SADDLE
417	P1006417	BOTTOM WAY COVER CLAMP
418-1	P1006418-1	WAY COVER ASSEMBLY
420	P1006420	LEADSCREW COLLAR
422	P1006422	LEFT FLANGE
423	P1005613	LONGITUDINAL LEADSCREW NUT
424	P1126224	LONGITUDINAL LEADSCREW
427	P1006427	TABLE GIB
428	P1006428	TABLE
428-1	P1006428-1	TABLE PLUG
429	P1006429	STOP BLOCK T-NUT 1/4-20
430	P1006430	SPACER
436	P1006436	HANDLE
700	P1006700	LOCK HANDLE
707	P1006707	KNURLED THUMB SCREW 1/4-20 X 3/8
708	P1006708	SCALE
709	P1006709	RIVET
710	P1006710	LOCK HANDLE BUSHING
711	PLW01	LOCK WASHER 5/16
712	P1006712	ANGLE VISE



Warning Labels Breakdown and List

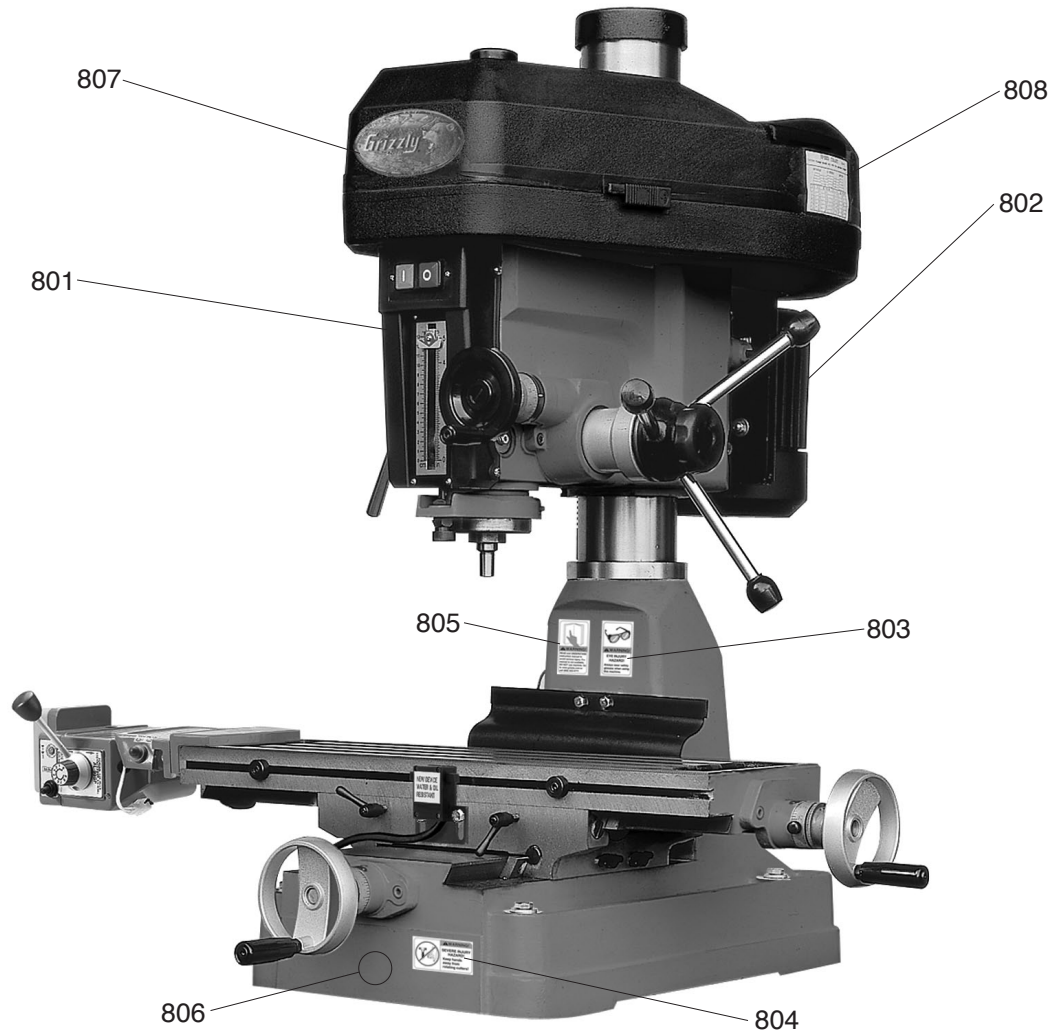

REF	PART #	DESCRIPTION
801	P1006801	MACHINE ID LABEL
802	PLABEL-14	ELECTRICITY LABEL
803	P1006803	WEAR GLASSES LABEL
804	P1006804	ROTATING CUTTER LABEL

REF	PART #	DESCRIPTION
805	P1006805	READ MANUAL LABEL
806	PPAINT-1	GRIZZLY GREEN TOUCH UP PAINT
807	G9987	GRIZZLY NAMEPLATE-MINI
808	P1006808	SPINDLE SPEEDS LABEL

WARNING

Safety labels warn about machine hazards and ways to prevent injury. The owner of this machine **MUST** maintain the original location and readability of the labels on the machine. If any label is removed or becomes unreadable, **REPLACE** that label before using the machine again. Contact Grizzly at (800) 523-4777 or www.grizzly.com to order new labels.

